

DOE-ID NEPA CX DETERMINATION

Idaho National Laboratory

SECTION A. Project Title: U.S. High Performance Research Reactor (HPPR) Low Enriched Uranium (LEU) Fuel Development

SECTION B. Project Description and Purpose:

Revision 4

The purpose of the project is to provide for a fission product release testing system that will support quantification of the release rates of fission products from the U-10Mo fuel system under hypothetical accident conditions. The system includes the furnace apparatus, associated piping systems (and connections to hot cell systems), and test samples. The major functions of the system are as follows:

- 1) Rapidly heat mini-plate samples of U-10Mo fuel (Note: mini-plates are 4" x 1" x 0.050" samples that consist of U-10Mo fuel clad in aluminum) beyond the U-10Mo melting temperature (1165 °C).
- 2) Perform the heating in air, argon, and argon+moisture environments.
- 3) Trap released vapor and aerosol fission products within an enclosed system and, as necessary, allow for the venting of fission product gases through the HFEF stack at levels that are acceptable to the HFEF facility.

The tested mini-plate samples will consist of both initially fresh and initially irradiated samples (irradiated at ATR) and will require re-irradiation in the Neutron Radiography (NRAD) reactor to generate sufficient quantities of short-lived radioisotopes to estimate pre-and post-test gamma count levels for specific isotopes. The data obtained from these tests will be used to support development of the safety basis for use of the U-10Mo fuel system in the ATR. The high-level steps in the experiment process are outlined below:

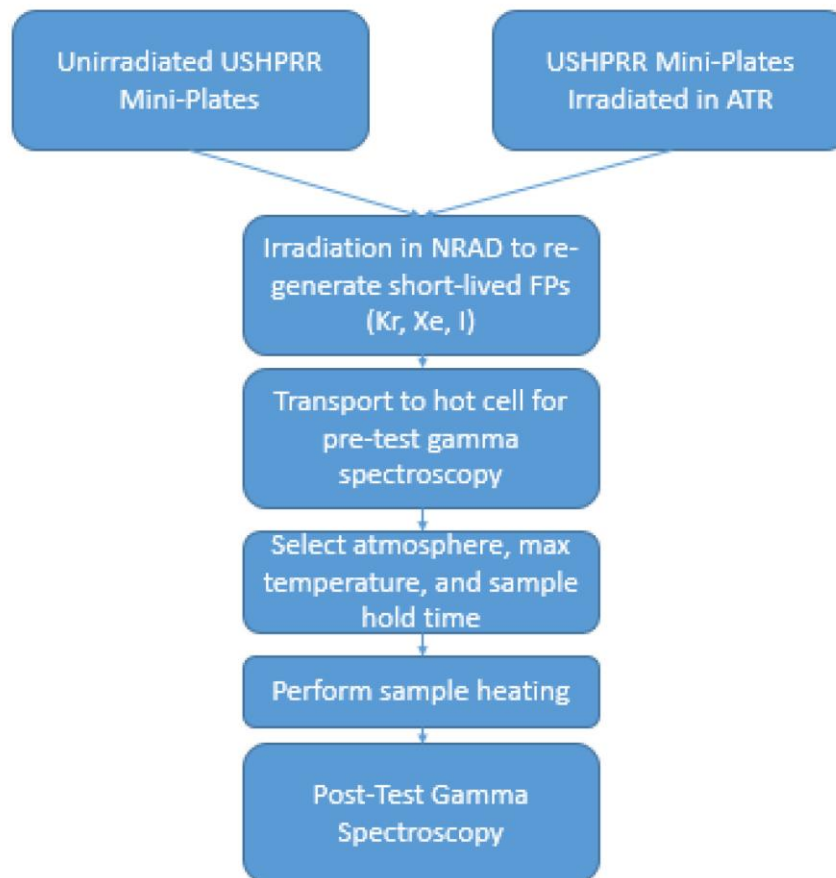

Summary of Overall Test Process

In addition, an overall system diagram and the major components and interfaces to HFEF facility is shown below. On the left-hand side of the diagram, gas supplies are shown. The gas supplies will feed the testing environmental gases into the hot cell via feedthrough connections to be fed into the furnace. Both air and argon gas supplies will be provided that will disperse moisture into an argon stream (e.g., a nebulizer). The moist atmosphere will be subsequently heated in the furnace environment. See Overall System Diagram below.

DOE-ID NEPA CX DETERMINATION

Idaho National Laboratory

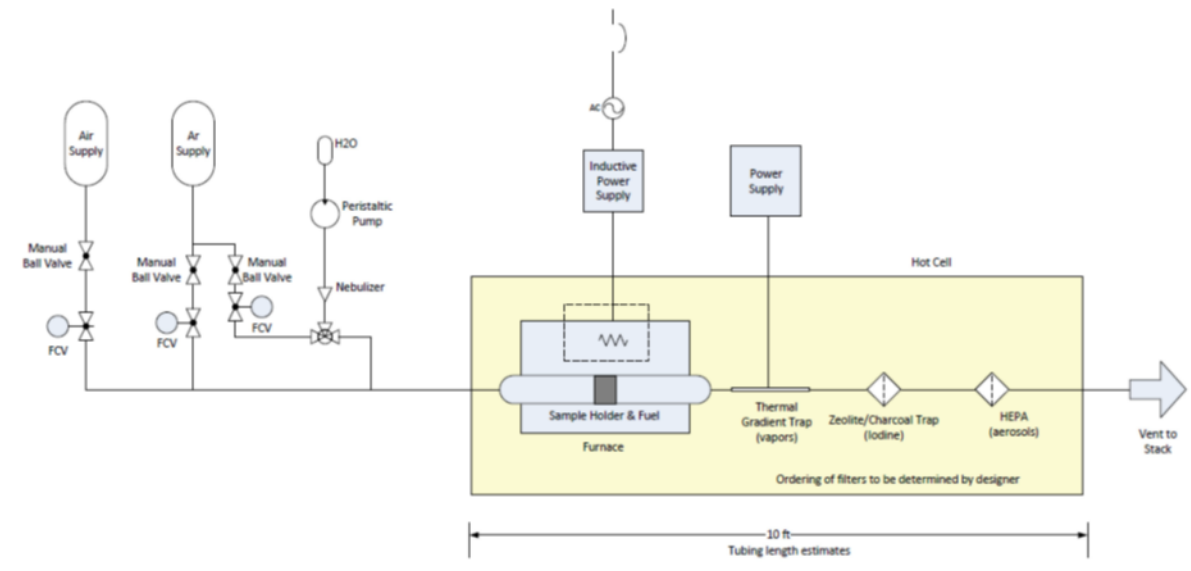

Revision 3

The purpose of this revision is to include the installation of the ATR Plate Scanner. The ATR Plate Scanner – Mark III will be installed in the ATR canal to support primarily the FSP-1 experiment but may also be used for FSP-ATR and FSP-HFIR. This plate scanner has been designated Mark III to distinguish it from previous plate scanners that have been used in the ATR canal. The plate scanner will support the United States High Performance Research Reactor – Fuel Qualification (USHPRR-FQ) program in its efforts to develop a low-enriched-uranium (LEU) fuel elements discussed in PLN-4291. The plate scanner is a non-destructive examination system (ultrasonic) that will measure the thicknesses of the fuel plates, cladding and fuel core regions. It will also be used to identify irradiation defects – if they occur – in the fully clad fuel portion of the plates.

Revision 2

The purpose of this revision is to capture scope for developing and qualifying a U-Mo monolithic fuel suitable for use in the University of Missouri Research Reactor (MURR). The revised scope adds testing of several Design Demonstration Elements (DDEs).

The proposed action irradiates the MURR DDE in the Advanced Test Reactor (ATR) northeast flux trap whereas the Element Test (ET)-1, ET-2, and ET-3 experiments are designed for insertion in ATR driver fuel position(s). For the ETs, FSP-1 must address ATR normal-power cycle irradiation conditions and be characterized after irradiation in the ATR canal by ultrasonic scanning to expedite insertion of ET-1. So, for the ET-1, ET-2, and ET-3, MURR DDE FSP-1 is a full size plate test representing either beginning-of-life (BOL) heat generation rate conditions of specific plates and end-of-life (EOL) burnup of other specific plates in these element tests. The FSP-1 test train requires the ability to irradiate up to six test plates, irradiate both full-size plates and smaller-scale test plates or conduct multiple irradiation insertions in order to provide adequate data for blister threshold testing.

The MURR DDE is close to the size of a full size MURR element. The MURR DDE fuel plates are the same size as the MURR element plates and the side plates are very similar to MURR. The main difference in the MURR DDE is the end caps that allow for channel gap measurements. The test will be designed to meet, as close as possible, the neutronic conditions of a typical MURR element. It will be considered a verification test to support LEU conversion of the MURR reactor.

Experiment assemblies for the ET-1, ET-2, and ET-3, and MURR DDE tests will be manufactured at BWXT in Lynchburg, VA from DOE owned materials and shipped to INL. Shipments use NRC licensed- and DOT-approved casks that comply with all applicable regulations. Fabrication of experiment support equipment, if necessary, would take place at fabrication facilities at REC, MFC or ATR. Once fabrication is complete, ATRC runs will be performed to determine the nuclear characteristics of the elements. Irradiation of the ET-1, ET-2, and ET-3 fuel elements in ATR requires an ATR Safety Analysis and Review (SAR) change (or SAR addendum). As previously stated, because an LEU fuel for conversion has not been designed, tested, or developed, fuel production and the physical and operational changes to convert the reactors once a fuel is qualified are beyond the scope of this EC. If conversion is determined to be feasible, and an LEU fuel is qualified, additional analysis in compliance with the National Environmental Policy Act (NEPA) will be performed to evaluate the physical and operational changes needed for full conversion and to disclose the environmental impacts associated with conversion.

Revision 1

The purpose of this revision is to capture additional project scope. The original EC analyzed the environmental impacts from the fabrication, irradiation, and post-irradiation examination of experiments and test elements to support the National Nuclear Security Administration's U.S. High Performance Research Reactor (USHPRR) program to convert high enriched uranium (HEU) fueled reactors to low enriched uranium (LEU) fuel. This revision adds receiving LEU

DOE-ID NEPA CX DETERMINATION

Idaho National Laboratory

fuel elements at the Nuclear Materials Inspection and Storage (NMIS) facility to support testing in the Advanced Test Reactor Critical (ATRC) facility, irradiation in the Advanced Test Reactor (ATR), and post irradiation examination (PIE) at the Materials and Fuels Complex (MFC).

The ATR LEU fuel elements are heavier than ATR HEU fuel elements. Therefore, storage of the ATR LEU elements requires modification of the NMIS facility storage rack shelves. The proposed action removes the wooden storage rack shelves and replaces them with a new metal design that eliminates cadmium sheets in the old shelves.

NMIS contains 29 storage racks that are about six feet high by two feet wide with eleven shelves each. Each rack is secured to the wall, floor and to the adjacent rack. The racks are composed of steel frames with 0.5 in. plywood (5-ply) and/or polyethylene shelving with wood dividers. Shelf construction also includes Masonite and cadmium sheets of 0.01 or 0.02 in. thick to allow neutron absorption between the shelves. New construction is anticipated to use metal shelves with non-toxic neutron poisons (boron). Racks contain only administratively controlled or specifically "allowed materials."

The original scope of work is included below:

The purpose of this work is to support the United States (U.S.) Department of Energy (DOE) U.S. High Performance Research Reactor (USHPRR) Program (herein referred to as the Program) and irradiation tests to support Advanced Test Reactor (ATR) low-enriched uranium (LEU) fuel development under the HPRR Program.

Idaho National Laboratory (INL) activities supporting the Program were analyzed in environmental checklists (ECs) INL-06-001 and INL-13-039 (revisions 1-3). This program was formerly known as the U.S. DOE /National Nuclear Security Administration (NNSA) Global Threat Reduction Initiative's (GTRI's) Reactor Conversion program and the Reduced Enrichment for Research and Test Reactors (RERTR) program. The Program minimizes the use of highly enriched uranium (HEU) in civilian applications by providing governments and facilities around the world with technical and economic assistance to convert research reactors to the use of non-weapons-usable low enriched uranium (LEU) fuels. The Program's mission is to reduce and protect vulnerable nuclear and radiological material located at civilian sites worldwide. The Program achieves this mission through three complementary initiatives:

1. Convert research reactors and radioisotope production facilities from the use of HEU to LEU
2. Remove and facilitate disposition of excess nuclear and radiological materials
3. Protect high priority nuclear and radiological materials from theft and sabotage.

Instances where suitable LEU fuels do not exist for reactors to convert, the Program contributes to the development of new LEU fuels. As no suitable LEU fuel is currently available with which these reactors could convert, the Program is researching LEU fuels and fabrication capabilities to determine if these reactors can be converted to LEU. The proposed action uses facilities at INL's Materials and Fuels Complex (MFC), ATR Complex, and in-town facilities such as the INL Research Center (IRC) to support research and development (R&D) activities in support of LEU fuel development for the Program, and proposed activities are consistent with current facility operations.

Research and development activities for this LEU fuel are comprised of four segments that are integrated until a qualifiable fuel has been developed. The four segments are Fabrication, Fresh Fuel Testing (FF), Irradiation and Post Irradiation Examination (PIE).

Fuel plates are fabricated primarily at the Fuels and Applied Science Building (FASB) (MFC-787) at MFC. Some experiments require a collaborative effort with fuel plates and plate materials being manufactured at Y-12 at Oak Ridge National Laboratory, Argonne National Laboratory East, Los Alamos National Laboratory (LANL), the Pacific Northwest National Laboratory (PNNL), and BWX Technologies, Inc. in Lynchburg, VA. After fabrication, the fuel plates are transported to MFC, the IRC for initial Fresh Fuel studies, or to the ATR for irradiation. After irradiation, the plates are shipped to MFC for PIE. Irradiated experiment transfers from ATR to MFC use a qualified shipping cask and the multi-purpose haul road when necessary.

Because an LEU fuel for conversion of ATR has not been designed, tested, or developed, fuel production and the physical and operational changes to convert the reactor once a fuel is qualified are beyond the scope of this EC. If conversion is determined to be feasible, and an LEU fuel is qualified, additional analysis in compliance with the National Environmental Policy Act (NEPA) will be performed to evaluate the physical and operational changes needed for full conversion and to disclose the environmental impacts associated with conversion. To gather the data needed to demonstrate that the requirements for base fuel qualification are met, well-defined test articles are fabricated, characterized, irradiated in ATR, and examined to quantify irradiation effects. Unirradiated components and fuels are examined to quantify the effects of fabrication variables on fuel performance, and to gather basic data on component and fuel properties in the absence of a radiation field. These activities are discussed below:

Out-of-Pile Testing and Analysis

Out-of-pile testing of unirradiated and irradiated fuel is conducted to collect data necessary to support qualification requirements and support fuel-performance modeling. These tests may be conducted on fuel plates prior to insertion in the reactor, on archive plates that are manufactured in parallel with plates that are irradiated, and on plates after irradiation. A major goal of out-of-pile testing is to understand the linkages between fabrication, microstructure, properties, and fuel performance.

Fresh fuel examination (FFE) occurs at MFC or IRC, and may include depleted uranium, low-enriched uranium, and high enriched uranium. PIE activities are conducted at the Hot Fuels Examination Facility (HFEF) at MFC. Fresh Fuel studies and PIE provide data on plate irradiation performance that feeds back to fabrication variables and provides data to help qualify the down-selected fuel system that meets performance requirements. These tests include:

DOE-ID NEPA CX DETERMINATION

Idaho National Laboratory

Blister Anneal Testing (PIE)—this test heats the fuel plate until the surface of the fuel plate blisters. This is required for fuel qualification since blistering is presented as a precursor to a breach of the fuel cladding. Blister anneal testing is a destructive examination and occurs in simple furnaces capable of reaching a maximum of 550°C.

Burn-up and SEM/TEM Sample Preparation, Clad Dissolution, Sample Measurements, and Bend Testing (PIE)—sample preparation is a destructive examination that sections irradiated plates then packages and transfers the materials to the appropriate PIE facility, such as the Electron Microscopy Laboratory and Analytical Laboratory. Dissolution of aluminum cladding is also conducted using a solution of NaOH. Dimensional measurements are taken on each sample. Mechanical testing is done in the load test frame in HFEF.

Disassembly Modeling (PIE)—disassembly of the capsules removes the fuel plates from the capsules without damaging the fuel plates. This is a non-destructive examination of the fuel plates.

Eddy Current (Oxide) (PIE)—eddy current measurements estimate the thickness of oxide that has grown on the fuel plates. This is a non-destructive examination of the fuel plates.

Fission Product Release (PIE)—fission gas release identifies fuel failure thresholds and measures fission product release to define allowable safety margins for U-Mo monolithic and dispersion fuel utilization. The type and movement of various fission product inventories determine source term data. This destructive examination of irradiated plates is performed in a furnace capable of reaching at least 2000°C.

Gamma Scanning (PIE)—the precision gamma scanner (PGS) scans irradiated experimental plates in both the transverse and axial directions. Gamma scanning determines the relative 2-D fission density gradient over a plate. This is a non-destructive examination of the fuel plates.

Immersion Density (PIE)—immersion density provides fuel swelling values for the entire plate and is used in the fuel qualification report as a fundamental fuel behavior property. This is a non-destructive examination of the fuel plates.

Laser Shock Bond Strength Testing (FF & PIE)—bond strength measurements assess the strength of cladding-to-fuel bonding in irradiated fuel plates. Testing uses laser generated shock waves to de-bond the fuel plate and laser ultrasonic inspection to characterize the interfaces.

Metallography (PIE)—metallography is a qualitative and quantitative measure. This is a destructive examination of irradiated plates requires sectioning and mounting small pieces of the irradiated fuel plate for examination in the microscope.

Microhardness (FF & PIE)—microhardness testing is done in the HFEF met box. This is destructive examination of irradiated plates requires sectioning and mounting small pieces of the irradiated fuel plate.

Neutron radiography (PIE)—neutron radiography identifies cracking in the fuel foil prior to sectioning. This is a non-destructive examination of the fuel plates. Profilometry (PIE)—profilometry determines local fuel swelling and is vital to the fuel qualification report. This is a non-destructive examination of the fuel plates.

Residual Stress (FF & PIE)—residual stress measurements give information about post irradiation mechanical state and plate failure mechanisms and involves incremental slitting of fuel plates combined with plate deflection measurements.

Visual Examination (FFE & PIE)—visual examinations of plates at HFEF identify anomalies, changes or defects that occur during irradiation or shipping. The examination uses a telephoto lens and camera and takes photos through the HFEF hot cell window. Photographs are taken of the front, back, and end of all capsules. This is a non-destructive examination of the fuel plates.

Fuel Qualification and Demonstration Testing

The irradiation tests and basic objectives for the tests that support ATR fuel qualification are listed below.

Mini-plate (MP) Testing

Mini-plate (MP) tests are small-scale tests used for scoping, selection of the fuel design, and statistical confidence. The small size of the test plates allows more than 30 test specimens to be investigated per test vehicle. Compared to full-size specimens, mini-plate testing investigates a wider variety of fabrication and fuel-performance variables, a wider range of irradiation conditions, and improves performance statistics reliability. Mini-plates are fabricated from full-size foil specimens and assembled into test plates using a fabrication process representative of commercial production.

MP-1—the MP-1 test provides information on fuel performance, in conjunction with fabrication studies, to select a LEU fuel design that meets fuel performance and fabrication requirements. MP-1 evaluates enough test plates to generate reliable blister threshold test results. A small number of specimens fabricated from previously tested laboratory-scale fabrication processes are included in the test matrix to compare known irradiation behavior with new fabrication processes.

MP-2—the MP-2 test plates are selected based on the outcome of MP-1 test. The MP-2 test establishes normal and off-normal operating conditions (from low to intermediate power density) for fuel performance of the geometrical plate designs, verifies fuel performance is repeatable, and generates data on blister-threshold temperature as a function of burnup. The MP-2 test is an initial demonstration of fuel fabricated with test plate designs specific to reactor conversion element designs, including thick fuel and thin cladding.

DOE-ID NEPA CX DETERMINATION

Idaho National Laboratory

Full-size Plate Testing (FSP)

Full-size plate testing provides proof of performance for prototypic-scale fuel geometries. Reactor conditions used in full-size plate tests are more prototypic and more representative of power profiles under reactor operating conditions than for MP tests. Full-size plate fabrication uses representative equipment and processes on a fuel production pilot line.

FSP-1—the FSP-1 test demonstrates irradiation performance for the selected monolithic fuel design on fuel plates at the size scale required for reactor conversion. Fuel selection based on the MP-1 test results determines the fuel-fabrication process for the FSP-1 test. FSP plates are fabricated at the same time as MP-1 plates. This test provides an important link between the base fuel design selection and the later geometry-specific qualification of fuel performed during demonstration of full-fuel-element performance.

The FSP-1 test precedes the ET-1 test elements for insertion in ATR driver fuel position(s). For this reason, FSP-1 must address ATR normal-power cycle irradiation conditions and be characterized after irradiation in the ATR canal by ultrasonic scanning to expedite insertion of ET-1. The FSP-1 test train requires the ability to irradiate up to six test plates, irradiate both full-size plates and smaller-scale test plates, or conduct multiple irradiation insertions in order to provide adequate data for blister threshold testing.

ET-1—the ET-1 test is an LEU driver fuel element in driver fuel positions of the Advanced Test Reactor (ATR) core and is considered a Lead Test Assembly (LTA). The ET-1 test uses the fuel-element design planned for eventual conversion of ATR to LEU fuel and serves to establish a base fuel qualification. ET-1 demonstrates prototypic fuel performance in a fuel element geometry (i.e., full-size, curved plates configured in a constrained fuel assembly). The test fabricates at least four ET-1 fuel elements and irradiates two. Each element is irradiated in the ATR in a driver core position, to be selected during design, under normal ATR operating conditions.

ET-2—following the ET-1 test, the Program conducts an ET-2 test using additional LEU elements at medium power levels and in more positions. These tests validate safety basis modeling and analysis efforts and build confidence in the use of the new fuel. This test irradiates 4 to 8 prototype ATR LEU conversion fuel elements in an ATR driver fuel position under operating conditions on the higher end of the normal-power range for ATR cycles.

ET-3—ET-3 is the final fuel qualification test before conversion of the ATR reactor. ET-3 irradiates about 8 prototype ATR LEU conversion fuel elements in any ATR driver fuel position under high-power ATR cycles within one ATR lobe. This test establishes the upper bound for higher power cycles sometimes referred to as powered axial locator mechanism (PALM) cycles.

Experiment assemblies for the ET-1, ET-2, and ET-3 tests will be manufactured at BWXT in Lynchburg, VA from DOE owned materials and shipped to INL. Shipments use NRC licensed- and DOT-approved casks that comply with all applicable regulations. Fabrication of experiment support equipment, if necessary, would take place at fabrication facilities at REC, MFC or ATR. Once fabrication is complete, ATRC runs will be performed to determine the nuclear characteristics of the elements. Irradiation of the ET-1, ET-2, and ET-3 fuel elements in ATR requires an ATR Safety Analysis and Review (SAR) change (or SAR addendum).

As previously stated, because an LEU fuel for conversion has not been designed, tested, or developed, fuel production and the physical and operational changes to convert the reactors once a fuel is qualified are beyond the scope of this EC. If conversion is determined to be feasible, and an LEU fuel is qualified, additional analysis in compliance with the National Environmental Policy Act (NEPA) will be performed to evaluate the physical and operational changes needed for full conversion and to disclose the environmental impacts associated with conversion.

Storage and Disposition

After PIE, irradiated materials and PIE remnants will be stored with other similar DOE-owned irradiated materials and experiments at MFC, most likely in the HFEF or the Radioactive Scrap and Waste Facility (RSWF) in accordance with DOE's Programmatic Spent Nuclear Fuel (SNF) Management and Idaho National Engineering Laboratory Environmental Restoration and Waste Management Programs Final Environmental Impact Statement (FEIS) and ROD (DOE/EIS-0203, 1995) and supplemental analyses (DOE/EIS-0203-SA-01 and DOE/EIS-0203-SA-02) and the Amended Record of Decision (February 1996). Ultimate disposal of the irradiated material and PIE remnants will be along with similar DOE-owned irradiated materials and experiments currently at MFC. Irradiated sample debris and secondary waste could total as much as 20-30 Kg. Categorizing this material as waste is supported under Department of Energy Order (DOE O) 435.1, Att. 1, Item 44, which states "...Test specimens of fissionable material irradiated for research and development purposes only...may be classified as waste and managed in accordance with this Order...".

In addition, to complete proposed work activities, it is necessary for the project to use the HFEF hot cell which contains both defense and nondefense related materials and contamination. Project materials will come into contact with defense related materials. It is impractical to clean out defense related contamination, and therefore, waste associated with project activities is eligible for disposal at the Waste Isolation Pilot Plant (WIPP). National Environmental Policy Act (NEPA) coverage for the transportation and disposal of waste to WIPP are found in Final Waste Management Programmatic Environmental Impact Statement [WM PEIS] (DOE/EIS-0200-F, May 1997) and Waste Isolation Plant Disposal Phase Supplemental EIS (SEIS-II) (DOE/EIS-0026-S-2, Sept. 1997), respectively. The 1990 ROD also stated that a more detailed analysis of the impacts of processing and handling transuranic (TRU) waste at the generator-storage facilities would be conducted. The Department has analyzed transuranic (TRU) waste management activities in the Final Waste Management Programmatic Environmental Impact Statement (WM PEIS) (DOE/EIS-200-F, May 1997). The WM PEIS analyzes environmental impacts at the potential locations of treatment and storage sites for TRU waste; SEIS-II addresses impacts associated with alternative treatment methods, the disposal of TRU waste at WIPP and alternatives to that disposal, and the transportation to WIPP.

DOE-ID NEPA CX DETERMINATION

Idaho National Laboratory

Packaging, repackaging, transportation, receiving, and storing used nuclear fuel and R&D for used nuclear fuel management is covered by DOE's Programmatic Spent Nuclear Fuel (SNF) Management and Idaho National Engineering Laboratory Environmental Restoration and Waste Management Programs Final Environmental Impact Statement (EIS) and Record of Decision (DOE/EIS-0203, 1995) and supplemental analyses (DOE/EIS-0203-SA-01 and DOE/EIS-0203-SA-02) and the Amended Record of Decision (February 1996). The analyses include those impacts related to transportation to, storage of, and research and development related to used nuclear fuel at the INL (see Tables 3.1 of the SNF Record of Decision (May 30, 1995) and Table 1.1 of the Amended Record of Decision [February 1996]).

The environmental impacts of transferring LLW from the INL Site to the Nevada National Security Site were analyzed in the 2014 Final Site-Wide Environmental Impact Statement for the Continued Operation of the Department of Energy/National Nuclear Security Administration Nevada National Security Site and Off-Site Locations in the State of Nevada (DOE/EIS-0426) and DOE's Waste Management Programmatic EIS (DOE/EIS-200). The fourth Record of Decision (ROD) (65 FR 10061, February 25, 2000) for DOE's Waste Management Programmatic EIS established the Nevada National Security Site as one of two regional LLW and MLLW disposal sites.

The potential for transportation accidents was analyzed in the SNF EIS (Section 5.1.5 and Appendix I-5 through I-10) and in the FRR EIS (Sections 4.2.1 and 4.2.2).

SECTION C. Environmental Aspects or Potential Sources of Impact:

Air Emissions

Note: If this project or activity produces or causes air emissions, and it is not stated in this ECP how those emissions caused by this project or activity are exempt, then an APAD is required for documentation. Emissions from the furnace will be discharged into a thermal gradient tube such that radioisotopes in vapor form deposit on the tube and then go through a combination of charcoal, zeolite or HEPA filters to trap radioactive aerosol fission products prior to the gas exiting into the facility radiological exhaust system. The facility exhaust is ran through several series of HEPA filter banks prior to its emission.

Discharging to Surface-, Storm-, or Ground Water

N/A

Disturbing Cultural or Biological Resources

HFEF is eligible for listing on the National Register of Historic Places (NRHP), and all project activities associated with the building must undergo cultural resource review (CRR). Contact INL CRMO (Reese Cook, 208.526.4029 or reese.cook@inl.gov) to initiate cultural resource review.

Generating and Managing Waste

During the project it is expected that small amounts of common trash and construction-related waste such as scrap metal will be generated. All scrap metal will be recycled to the extent practicable. Following completion of the experiment the filtration system may be disposed of as either RHLLW or CHLLW, which is anticipated to be approximately 0.2 cubic meters.

Releasing Contaminants

All chemicals typically used will be managed in accordance with laboratory procedures. All chemicals and associated Safety Data Sheets (SDS's) must be submitted in the vendor data system for approval. The Chemical Coordinator would track these chemicals in the INL Comply Plus Chemical Management System. Chemical use has a potential for small air emissions and spills. In the event of a spill, notify MFC Environmental staff. If the MFC Environmental Manager cannot be contacted, report the release to the Spill Notification Team (208-241-6400). Clean up the spill and turn over spill cleanup materials to Waste Generator Services.

Using, Reusing, and Conserving Natural Resources

All material will be reused and/or recycled where economically practicable. All applicable waste would be diverted from disposal in the landfill when possible. Project personnel would use every opportunity to recycle, reuse, and recover materials and divert waste from the landfill when possible. The project would practice sustainable acquisition, as appropriate and practicable, by procuring materials that are energy efficient, water efficient, are bio-based in content, environmentally preferable, non-ozone depleting, have recycled content, and are non-toxic or less toxic alternatives.

SECTION D. Determine Recommended Level of Environmental Review, Identify Reference(s), and State Justification: Identify the applicable categorical exclusion from 10 Code of Federal Regulation (CFR) 1021, Appendix B, give the appropriate justification, and the approval date.

DOE-ID NEPA CX DETERMINATION

Idaho National Laboratory

For Categorical Exclusions (CXs), the proposed action must not: (1) threaten a violation of applicable statutory, regulatory, or permit requirements for environmental, safety, and health, or similar requirements of Department of Energy (DOE) or Executive Orders; (2) require siting and construction or major expansion of waste storage, disposal, recovery, or treatment or facilities; (3) disturb hazardous substances, pollutants, contaminants, or Comprehensive Environmental Response, Compensation, and Liability Act (CERCLA)-excluded petroleum and natural gas products that pre-exist in the environment such that there would be uncontrolled or unpermitted releases; (4) have the potential to cause significant impacts on environmentally sensitive resources (see 10 CFR 1021). In addition, no extraordinary circumstances related to the proposal exist that would affect the significance of the action. In addition, the action is not "connected" to other action actions (40 CFR 1508.25(a)(1) and is not related to other actions with individually insignificant but cumulatively significant impacts (40 CFR 1608.27(b)(7)).

References: 10 CFR 1021, Appendix B, B3.6, "Small-scale research and development, laboratory operations, and pilot projects" and B1.31 "Installation or relocation of machinery and equipment"

Programmatic Spent Nuclear Fuel Management and Idaho National Engineering Laboratory Environmental Restoration and Waste Management Programs Final Environmental Impact Statement and Record of Decision (DOE/EIS-0203, 1995) and supplemental analyses (DOE/EIS-0203-SA-01 and DOE/EIS-0203-SA-02) and the Amended Record of Decision (1996).

Final Site-Wide Environmental Impact Statement for the Continued Operation of the Department of Energy/National Nuclear Security Administration Nevada National Security Site and Off-Site Locations in the State of Nevada (DOE/EIS-0426, December 2014).

Final Environmental Impact Statement for the Waste Isolation Pilot Plant (DOE/EIS-0026, October 1980) and Final Supplement Environmental Impact Statement for the Waste Isolation Pilot Plant (SEIS-I) (DOE/EIS-0026-FS, January 1990).

Final Waste Management Programmatic Environmental Impact Statement [WM PEIS] (DOE/EIS-0200-F, May 1997) and Waste Isolation Plant Disposal Phase Supplemental EIS (SEIS-II) (DOE/EIS-0026-S-2, Sept. 1997).

Final Environmental Assessment (EA) for the Consolidation and Expansion of Idaho National Laboratory Research and Development at a Science and Technology Campus and Finding of No Significant Impact (DOE/EA-1555, March 2007).

Justification: Project activities are consistent with 10 CFR 1021, Appendix B, B3.6, "Siting, construction, modification, operation, and decommissioning of facilities for small-scale research and development projects; conventional laboratory operations (such as preparation of chemical standards and sample analysis); and small-scale pilot projects (generally less than 2 years) frequently conducted to verify a concept before demonstration actions provided that construction or modification would be within or contiguous to a previously disturbed or developed area (where active utilities and currently used roads are readily accessible). Not included in this category are demonstration actions, meaning actions that are undertaken at a scale to show whether a technology would be viable on a larger scale and suitable for commercial deployment." and,

B1.31, "Installation or relocation and operation of machinery and equipment (including, but not limited to, laboratory equipment, electronic hardware, manufacturing machinery, maintenance equipment, and health and safety equipment), provided that uses of the installed or relocated items are consistent with the general missions of the receiving structure. Covered actions include modifications to an existing building, within or contiguous to a previously disturbed or developed area, that are necessary for equipment installation and relocation. Such modifications would not appreciably increase the footprint or height of the existing building or have the potential to cause significant changes to the type and magnitude of environmental impacts."

The environmental impacts of transferring LLW from the INL Site to the Nevada National Security Site were analyzed in the 2014 Final Site-Wide Environmental Impact Statement for the Continued Operation of the Department of Energy/National Nuclear Security Administration Nevada National Security Site and Off-Site Locations in the State of Nevada (DOE/EIS-0426) and DOE's Waste Management Programmatic EIS (DOE/EIS-200). The fourth Record of Decision (ROD) (65 FR 10061, February 25, 2000) for DOE's Waste Management Programmatic EIS established the Nevada National Security Site as one of two regional LLW and MLLW disposal sites.

The impacts of transporting and disposing of waste resulting from defense activities that was placed in retrievable storage pursuant to a 1970 Atomic Energy Commission policy (see Section 1.2) and TRU waste that was reasonably expected to be generated by ongoing activities and programs was analyzed in DOE/EIS-0026 (October 1980) and the Final Supplement Environmental Impact Statement for the Waste Isolation Pilot Plant (SEIS-I) (DOE/EIS-0026-FS, January 1990).

NEPA coverage for the transportation and disposal of waste to WIPP are found in DOE/EIS-0200-F (May 1997) and Waste Isolation Plant Disposal Phase Supplemental EIS (SEIS-II) (DOE/EIS-0026-S-2, Sept. 1997), respectively. The 1990 ROD also stated that a more detailed analysis of the impacts of processing and handling TRU waste at the generator-storage facilities would be conducted. DOE has analyzed TRU waste management activities in DOE/EIS-200-F (May 1997). The WM PEIS analyzes environmental impacts at the potential locations of treatment and storage sites for TRU waste; SEIS-II addresses impacts associated with alternative treatment methods, the disposal of TRU waste at WIPP and alternatives to that disposal, and the transportation to WIPP. (SEIS-II also includes potential transportation between generator sites.)

The impacts of conducting radiological research at INL's in-town facilities were analyzed in DOE/EA-1555 (March 2007) section 4.2.2.

DOE-ID NEPA CX DETERMINATION
Idaho National Laboratory

Is the project funded by the American Recovery and Reinvestment Act of 2009 (Recovery Act) Yes No

Approved by Jason L. Anderson, DOE-ID NEPA Compliance Officer on: 11/15/2021