

# DOE-ID NEPA CX DETERMINATION

## Idaho National Laboratory

**SECTION A. Project Title:** Dynamic Energy Transport and Integration Laboratory, Microreactor Agile Non-Nuclear Experiment Test Bed, Thermal Energy Delivery System, and High Temperature Electrolysis Demonstration Systems

**SECTION B. Project Description and Purpose:**

This Revision addresses the construction and operation of multiple high temperature electrolysis (HTE) demonstration systems that will be located in a cargo container that will be adjacent to Energy Systems Laboratory building (IF-685). The plan is to fabricate and test a prototype 50 kW system in early 2021 and also test a similar 120 kW provided by Bloom Energy later in 2021. Larger systems, up to 250 kW, will be tested in 2022. If the prototype 50 kW system work is successful, subsequent NEPA analysis performed as necessary for the subsequent demonstration systems.

The process flow diagram of the prototype 50 kW system is provided in Figure 1. A computer-aided design (CAD) model of the system is shown in Figure 2. Major components include air filter/dryer, high temperature air heater, high temperature electrolysis stack box (stack box), high temperature heat recuperator box (recuperator box), hydrogen gas cylinder, reducing gas cylinder, mass flow controllers, de-ionized water supply, electric steam generator, connection to the Thermal Energy Distribution System (TEDS) steam generator, high temperature steam-hydrogen heater, high temperature solid oxide electrolysis cells (SOEC) stacks, exhaust steam-hydrogen condenser (air cooled), hydrogen recycle blower, and AC/DC rectifier/inverter (not shown in Figure 1).

Figure 1. Process flow diagram

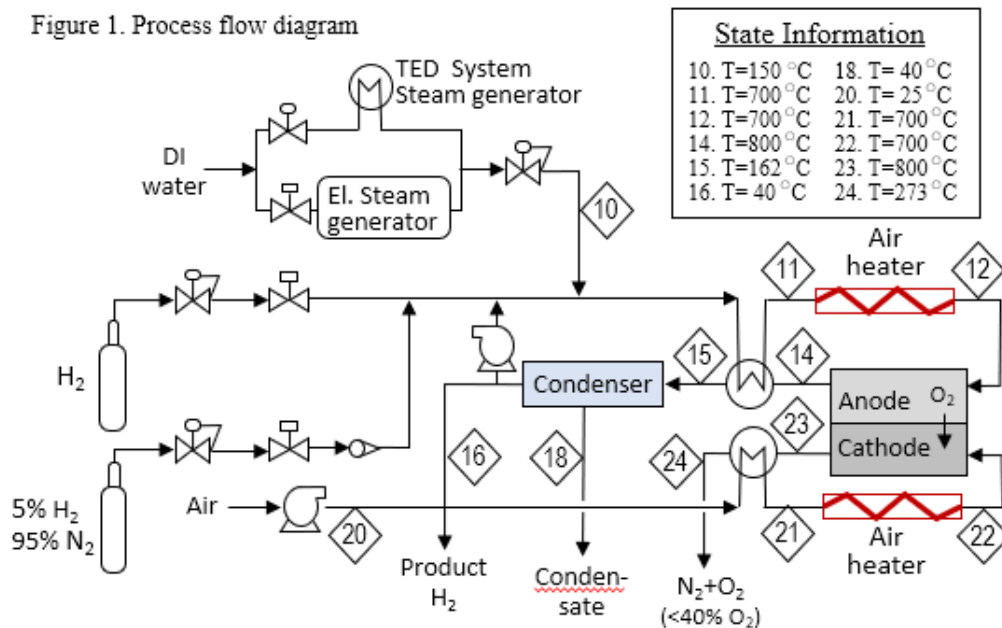
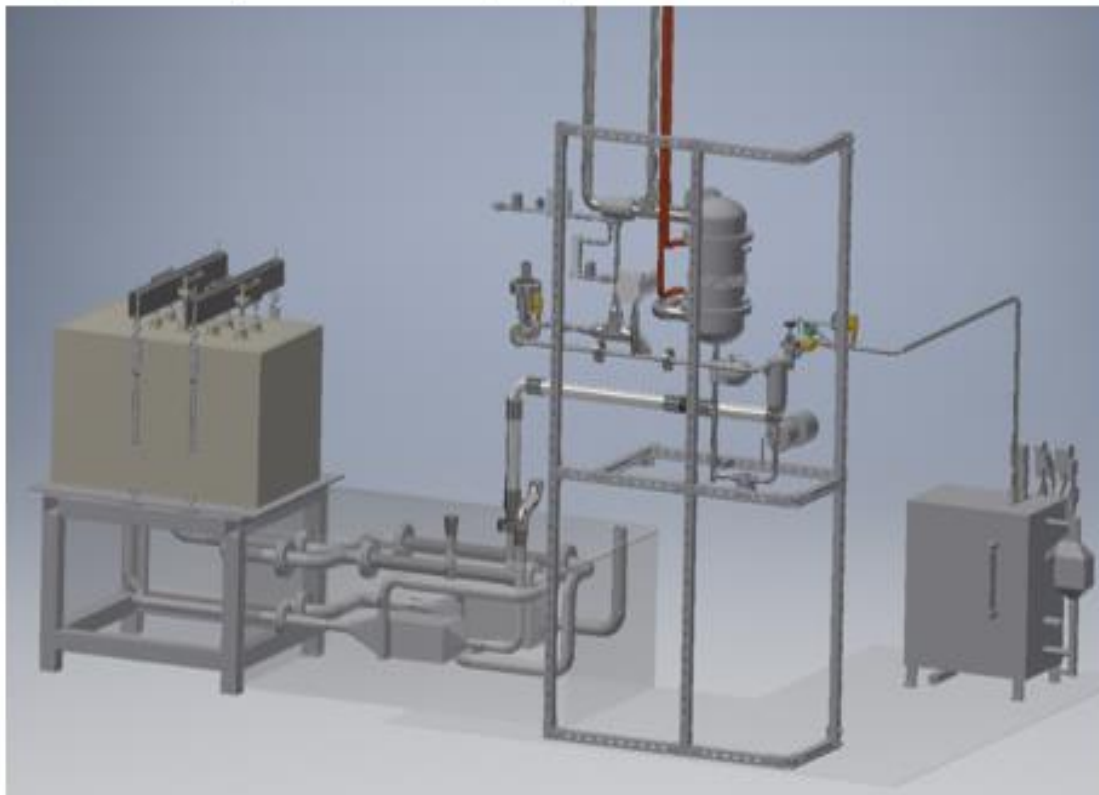

Figure 2. Computer aided drawing of system.



Piping and related components of the prototype and future demonstration systems will be per ASME B31.3 Process Piping. Incoming air (Stream 20 in Figure 1) will be preheated by passing it through a heat exchanger that recovers heat from exhaust air. Incoming air also passes through an inline air heater that will only operate during the start-up transient to heat the system or during times in which the power utilization is too low to provide sufficient heat from the heat exchangers. Air flow will be sufficient at all times to ensure that the air exhaust, which includes additional oxygen from the water splitting reaction, does not contain more than 40% oxygen molar concentration. Steam for the system will come from either an electric steam generator or from a heat exchanger (steam generator) connected to the TED system. During system start-up, air will flow through the system and will be heated by the air heater. A reducing gas consisting of 5-10% H<sub>2</sub> and 90-90% N<sub>2</sub> will also flow through the system when the temperature of the air is hotter than 300°C. When the H<sub>2</sub> electrode exhaust temperature reaches 700°C, H<sub>2</sub> from a pressurized tank and steam from the steam generator are flowed into the unit at a mixing ratio

# DOE-ID NEPA CX DETERMINATION

## Idaho National Laboratory

of 5-10% H<sub>2</sub> and 90-95% steam. The electric bus contactors are closed and voltage is applied to ramp the system up to predetermined electric current flow and hydrogen generation set points. The hydrogen recycle blower turns on to recycle H<sub>2</sub> back onto the anode side of the SOEC stack, and the reducing gas and H<sub>2</sub> gas supplies are shut. The inline heaters remain on until the recuperated heat transfer can heat the inlet fluids to the inlet temperature set point. During operation, excess steam is always fed to the SOEC cells, such that steam utilization is always less than 65%. The steam-hydrogen mixture exiting the SOEC stacks is passed through a air-cooled condenser that separates H<sub>2</sub> from condensate. The H<sub>2</sub> is vented through a chimney to atmosphere, and the condensate (deionized water) is drained to Idaho Falls city sewer.

In a controlled shutdown, the electric current, steam input, and recycled hydrogen flows are ramped down until the current reaches approximately 1 A, the current and H<sub>2</sub> are shut off, and reducing gas is allowed to flow. Air flow is reduced to a minimum value, the inline heaters are turned on, and the system is allowed to cool at a rate of 2°C/min. Once the system cools such that the cathode and anode exhaust is less than 200°C, the reducing gas and air flow are shut off, and the system is placed in idle mode. In an emergency shutdown or sudden, unexpected loss of power, the air blower, H<sub>2</sub> recycle blower, and the steam generators will shut off. The valves on the reducing gas are set to fail open in the event of loss of power, so that reducing gas will flow while the system cools. All covers and insulation will be left in place to allow the system to cool as slowly as possible without heat input. The system can also operate in hot idle mode in which the electric bus contactor is open, so that no current flows and H<sub>2</sub> is not produced. In this mode, air and reducing gas continue to flow and the inline heaters powered on to maintain system temperature.

As noted above, steam will either be provided by an electric steam generator or by the heat exchanger connected to the TEDS. The electric steam generator will be a Chromalox stainless steel vertical steam boiler (Model CSSB-100A) that uses 102 kW to produce up to 307 lbs/hr steam at 100°C. the TEDS steam generator/heat exchanger will transfer heat from Therminol 66 heat transfer oil in the TEDS to boil DI water and heat the steam to approximately 150°C. All of the equipment in this system, except the TEDS steam generator will be placed inside a 20 ft x 8 ft cargo container that will be outside of ESL D-100. The footprint of the piping system, including the stack box and recuperator box is approximately 10 ft x 4 ft (shown in Figure 2), which leaves room in the cargo container for support equipment, including the power inverter and electrical panels. Compressed gas cylinders will be stored on racks outside of the cargo container. The cargo container will be continuously vented whenever testing is in progress. Oxygen and hydrogen monitors will be installed inside the cargo container. Alarms will indicate the presence of leaked hydrogen or oxygen outside of the expected atmospheric range (<19% or >23%).

The first system being developed and tested in 2021 will be designed to consume a maximum of 50 kW to produce 1.2 kg of hydrogen per hour and 10 kg of oxygen per hour. Air flow will be approximately 30 kg/hr to maintain the oxygen concentration at the outlet to less than 40%. This system will be placed in the backyard of the Energy System Laboratory (ESL or IF-685) D wing highbay, as shown in Fig. 3. DI water will be fed into the system at a maximum rate 18.6 kg/hr and will be heated in a steam generator (electric or connected to the TEDS) to 150°C, requiring a maximum thermal power of approximately 14 kW. Product hydrogen will contain steam that will be condensed and released to drain at a maximum rate of 7.4 kg/hr. The second system being tested in 2021 and which will be provided by Bloom Energy will be approximately 2 times larger and will have similar operation. It will be placed alongside the 50 kW system and will use the same electrical and steam connections. It will consume a maximum of 120 kW to produce approximately 3 kg of hydrogen per hour and 24 kg of oxygen per hour. DI water will be fed into the system at a maximum rate of 45 kg/hr, requiring a maximum thermal power of approximately 33 kW. Condensate water will be produced and released to drain at a maximum rate of 18 kg/hr.

DOE-ID NEPA CX DETERMINATION  
Idaho National Laboratory

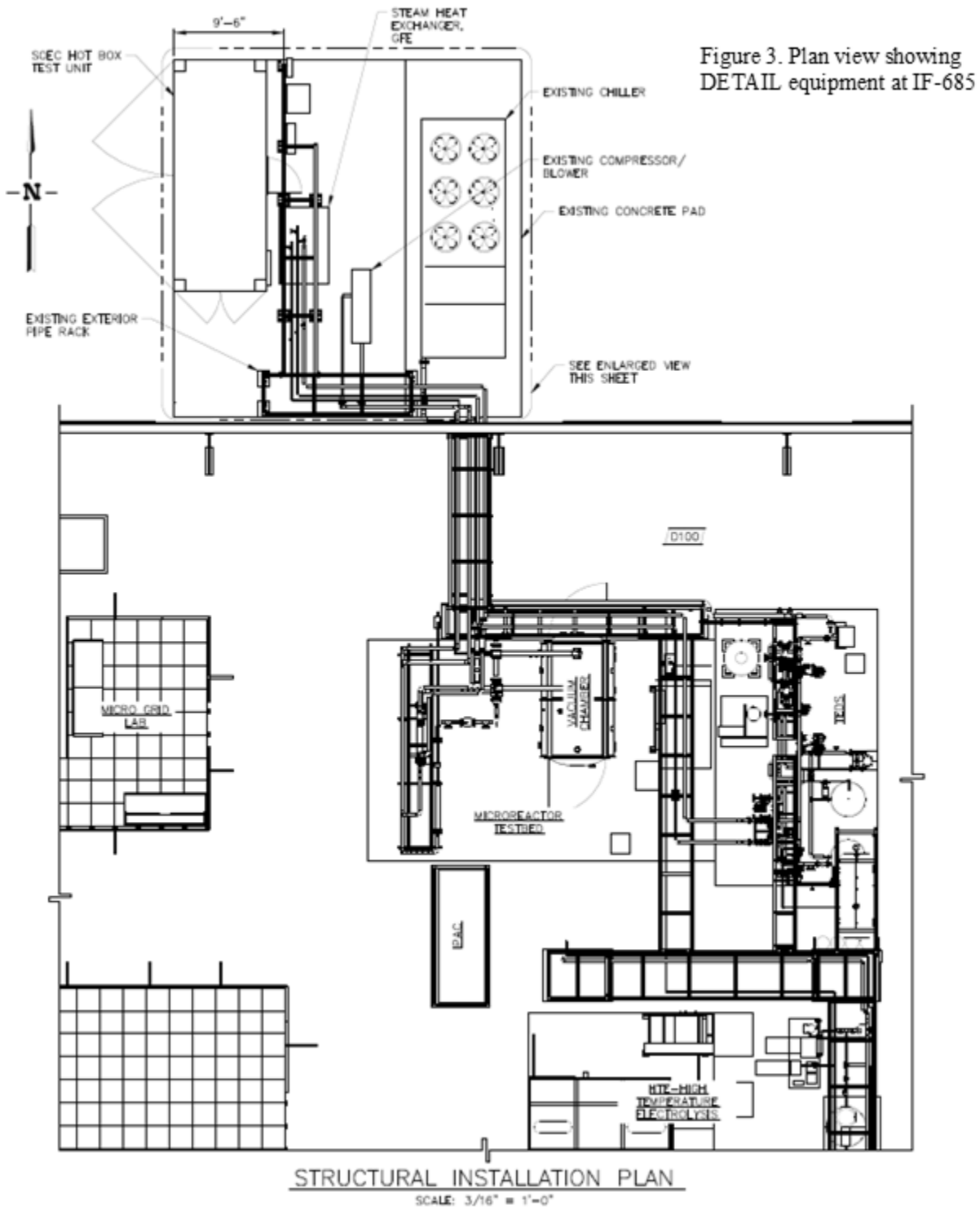

Figure 3. Plan view showing  
DETAIL equipment at IF-685

# DOE-ID NEPA CX DETERMINATION

## Idaho National Laboratory

### Revision 1

This environmental checklist (EC) is being revised as a 1st tier document to address activities that are not covered in the previously referenced overarching EC and to provide additional information about the Dynamic Energy Transport and Integration Laboratory (DETAIL) at the Energy Stems Laboratory (ESL) at Idaho National Laboratory (INL) within the Energy Systems Laboratory (ESL) D100 northwest high bay. Activities previously evaluated in ECs INL-19-102 "Micro-reactor Testbed, Instrumentation and Sensors (for sodium filled heat pipes)" and INL-19-045 (OA 18 & 27) "High Temperature Electrolysis Demonstration Facility" have been incorporated into this EC, because both the non-nuclear microreactor test bed and high temperature electrolysis facility are components of DETAIL that need to be evaluated as a single action to meet the requirements of the National Environmental Policy Act (NEPA). This EC supersedes ECs INL-19-045 (OA 18 & 27) and INL-19-102.

Research regarding Nuclear- Renewable Hybrid Energy Systems (NR-HES) continues to increase as wind and solar grid penetrations continue to increase. Sensible heat Thermal Energy Storage (TES) systems have been shown to be an effective thermal load management strategy allowing nuclear reactor systems to operate at effectively 100% full power while storing excess thermal energy for recovery later. Thermal storage has been modeled extensively around the world. However, little experimentation is being conducted. Experimentation is needed to verify the dynamics and control of TES systems. Idaho National Laboratory (INL) designed a Thermal Energy Delivery System (TEDS) to distribute thermal energy to and from various co-located systems located in the DETAIL. INL proposes to install these systems in the Energy Systems Laboratory (ESL) D100 northwest high bay as shown in Figure 1.1.

Figure 1.1 Location of DETAIL in the ESL D100 highbay.

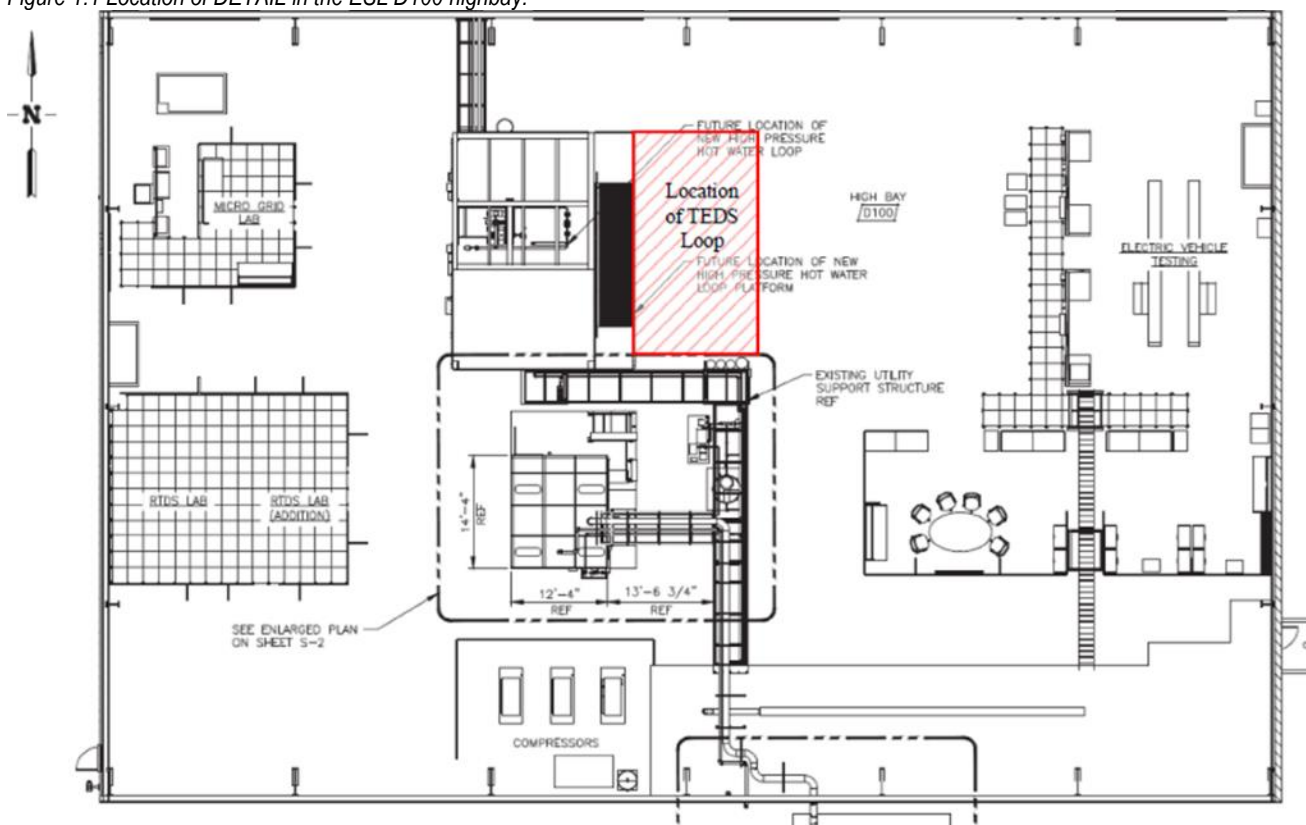

DETAIL is made of multiple heat and electricity producers, thermal and electrical storage systems, and multiple heat and electricity customers coupled via a thermal and electrical network. This system supports research and development efforts that evaluate real-time integration between the electrical grid, renewable energy inputs, energy storage, and energy users to understand how to optimize energy flows while maintaining stability and efficient operation of system assets. DETAIL includes the following components:

- Microreactor Agile Non-nuclear Experimental Testbed (MAGNET)
- TEDS
- High Temperature Electrolysis (HTE) demonstration facility (hydrogen generation)
- Real-time virtual linkage with multiple test facilities.

Within DETAIL, the water flow loop serves as a thermal energy source, emulating a reactor system. INL integrates the loop with co-located energy systems including a thermal energy transport loop, thermal energy storage system, and a 25 kW high temperature electrolysis system for hydrogen production. DETAIL includes additional energy systems such as an integrated microgrid and renewable energy systems including solar photovoltaics. The various components interface with Digital Real-Time Simulators for supervisory control and dynamic simulation of complete systems. The following discussion details these components:

### MAGNET

Microreactors (i.e., very small transportable or mobile nuclear reactors with a capacity less than 20 MWt) are being developed to supply heat and power for various applications in remote areas, military installations, emergency operations, humanitarian missions, and disaster relief zones. A wide variety of reactor types are under consideration, including sodium-cooled fast reactors, molten salt reactors, light water reactors, very high-temperature gas reactors, and heat

# DOE-ID NEPA CX DETERMINATION

## Idaho National Laboratory

pipe reactors. These miniaturized transportable reactor designs remain largely untested and unproven. System and component testing are needed to demonstrate design safety and system robustness, reliability and efficiency.

The Department of Energy (DOE) Office of Nuclear Energy's (NE) Micro-Reactor Research, Development, and Deployment (RD&D) Program manages national laboratory-led early-stage generic research and technology development for micro-reactor systems and provides cost-shared support for micro-reactor vendor development and licensing activities through the DOE-NE Industry Funding Opportunity Announcement. The program also coordinates efforts between the Department of Defense (DoD), industry, and Nuclear Regulatory Commission (NRC) to support the demonstration of micro-reactor technology on a DOE national laboratory site. National laboratories supporting the Micro-Reactor Program include INL, Oak Ridge National Laboratory (ORNL), Los Alamos National Laboratory (LANL), Argonne National Laboratory (ANL), and Sandia National Laboratory (SNL).

As DOE's lead laboratory for nuclear energy, INL has taken the role of the lead laboratory for the micro-reactor program. To support these efforts, INL proposes designing a non-nuclear micro-reactor test bed (NMTB) to assist developing, demonstrating, and validating micro-reactor components and systems. The test bed supports technology maturation to reduce uncertainty and risk relating to operating and deploying micro-reactor systems. Systems and components can be safely tested to failure at the NMTB, giving valuable information regarding failure modes and thresholds. Potential users of the NMTB include micro-reactor developers, energy users, and regulators. Regulators can be engaged early in the design and testing to expedite regulatory approval and licensing.

The test bed includes an enclosure for housing test articles, electrical heaters, cooling system, instruments and sensors, and data acquisition hardware and is configured in a plug-and-play arrangement. Modeling and simulation (M&S) will be employed to design experiments, and the collected data will be used to validate models. This information guides the placement of sensors and helps predict operating performance under a range of normal, off-normal or accident conditions. M&S is also valuable for scaling prototypical hardware for each test. Computational control and model feedback will be pursued to emulate thermal response times and magnitudes of an operating reactor. The overall objective is to test components and systems to verify the safe, reliable and efficient operation of micro-reactor designs.

INL proposes to install the test bed in Energy Systems Laboratory (ESL) Bay D100 but will complete preliminary experiments with single heat pipes at the Bonneville County Technical Center (BCTC) high bay. INL will initially procure heat pipes from Advanced Cooling Technologies. The heat pipes use electrical cartridge heaters located in a mono Hex block and are instrumented with thermocouples, distributed temperature sensors, and pressure sensors. Preliminary experiments familiarize INL staff with the operation of heat pipes and aid in developing computer models (Sockeye) for predicting heat pipe performance. The working temperature for preliminary work is not expected to exceed 750°C and the maximum internal pressure will be below atmospheric pressure.

MAGNET is being designed with the following goals:

1. Give displacement and temperature field data to verify design performance and validate analytical models
2. Show core block structural integrity (i.e., evaluate thermal stress, strain, aging/fatigue, creep, deformation)
3. Evaluate interface between reactor components and heat exchanger for geometric compatibility, heat pipe functionality, and heat transfer capabilities
4. Test interface of the heat exchanger to power conversion systems for energy production or for process heat applications
5. Demonstrate advanced manufacturing (AM) techniques, such as additive manufacturing, such as diffusion bonding and hipped-powder metallurgy, for nuclear reactor applications
6. Identify and develop advanced sensors and power conversion equipment, including instruments for autonomous operation
7. Study the effects of cyclic loading on materials and components for load-following applications
8. Enhance readiness of the public, stakeholders, DOE laboratories, and the US NRC to design, operate and test high-temperature reactor components.

The test bed requires the ability to simulate the operational envelope of the micro-reactor. The micro-reactor system includes the reactor core, surrounding reflectors, coolant, containment vessel, and heat exchangers. Auxiliary systems to produce electricity or commodities, such as the power conversion unit, desalination equipment, chemical conversion, and district heating, can be attached to the test bed to demonstrate the utility of these systems. However, such systems must be configured as self-contained plug-ins.

### Testing Approach

The program adopts a phased development approach. Heat pipe reactors offer the simplest starting point for integrated testing. The initial set of tests consist of:

1. A single core monolith block with holes for fuel rods and heat pipes to understand heater interface and block response
2. A single heat pipe experiment to obtain flow and temperature data
3. A larger scale article where the monolith and heat pipes (~37) interface with heat exchangers understand the power mechanism driving all heat pipe micro-reactor designs.

The first testing phase examines heat pipe technology, starting with general heat pipe and heat exchanger tests. Additional geometries and specialized heat pipe reactor designs may also be tested. Researchers design geometrical prototypes to represent fabrication details of the core and the heat exchangers (including but not limited to types of welds and bonds). The initial design includes direct air-cooled heat-exchangers at lower pressures although supercritical-CO<sub>2</sub> microchannel heat exchangers at higher pressures may be evaluated in the future. INL is considering using nitrogen recirculating in the heat exchanger to decrease oxidation risk for test articles. Initial core tests will be monolithic although future tests may include a shell-and-tube type heat exchanger. Initial tests compare measured temperatures to validate finite element analysis (FEA) predictions.

The second phase of testing focuses on gas-cooled designs. In a gas-cooled design, reactor internal temperatures across the core can vary by as much as 300 to 400°C, while the core pressure could be as high as 1000 psi. Thermal transients lead to creep and creep-fatigue damage. Prototype reactor geometries will be fabricated and tested.

The system requires connecting to facility electrical power, facility exhaust, and various gas supplies including compressed air. The system will have the ability to interface with the microgrid test bed. The entire unit will be configured to accommodate testing indoors in the ESL high bay.

### System Description

INL employs electrical heaters to simulate the heat generated by the nuclear fuel rods.

# DOE-ID NEPA CX DETERMINATION

## Idaho National Laboratory

### *Instrumentation*

Instruments having enough resolution to validate high-fidelity computer codes measure and monitor specified experiment parameters. This data is recorded directly to INL's high performance computing enclave. The specific types of instrumentation to be provided may include:

- Ultrasonic pulsed arrays – Piezoelectric sensors and actuators that excite the structure using a subset of the piezoelectric patches and record the response using other piezoelectric patches.
- Acoustic emission sensors – Cracking or other damage to the monolithic structure emits an acoustic signal that can be detected acoustic sensors
- Laser Doppler vibrometer with steering mirror – The laser Doppler vibrometer acts in a stand-off manner and detects corrosion
- Interferometry coupled with full-field, high resolution video-based structural dynamics – record full-field, high-resolution shapes of vibrating structures using video.
- Accelerometers – Measure the resonant frequencies, mode shapes and damping ratios of the monolith.
- Thermal imagers – Record temperature distribution across the test article.
- Strain gauges and stand-off displacement sensors – These detect monolith damage resulting in structural deformation.
- X-ray CT scans – Track two-phase flow.
- Barkhausen noise sensor – Monitor crystallographic changes in metal.
- High-speed digital image correlation – Obtain in situ strain at surface.
- Wireless embedded sensors – Used where possible.
- Thermocouples – Mounted to test article.
- Distributed fiber optic temperature sensors – Mounted to test article.
- Flux sensors – Characterize electrical noise.
- Mass flow and pressure – Temporal measurements.

### *Data requirements*

The system can be accessed locally or remotely via a 100 GB data network. Test data directly feeds to the INL High Performance Computing (HPC) enclave. ESL supplies data acquisition computers and workstations for test engineers and vendor representatives. Arrangements for handling of proprietary data must be pre-arranged and applicable non-disclosure agreements (NDAs) in place before testing commences. Export control of the design configuration and test data may be necessary. The HPC interface, cyber security, data access and storage will be considered. All data stored in accessible server.

### *Equipment*

Initial equipment purchased will include 2 sodium filled heat pipes, 15 electrical heaters, 2 stainless steel mono blocks, temperature sensors, and data acquisition equipment. The initial full test article will include 37 heat pipes supplied by Los Alamos National Laboratory and 54 cartridge heaters with a length of one meter. The project will start in October 2019 and will be completed in 2025.

### **Thermal Energy Distribution System**

To further complement the modeling and simulation efforts on NR-HES systems, INL is designing a Thermal Energy Delivery System (TEDS). The system distributes thermal energy to and from various co-located systems within the DETAIL. The thermal energy transfer from TEDS can be used to support test and demonstration operations for N-R HES applications. INL designed TEDS so the DETAIL water flow loop can be expanded to supply thermal energy to systems integrated into the DETAIL testbed over time with minimal disruptions to DETAIL testbed operations. TEDS helps understand the cyclic behavior (charging and discharging characteristic) of thermal energy storage systems and the system's dynamic behavior with integrated industrial applications, and yields much-needed feedback for control systems to support DETAIL test/demonstration operations. Figure 1.2 shows the process flow diagram for TEDS.

*Figure 1.2. Process flow diagram for TEDS.*

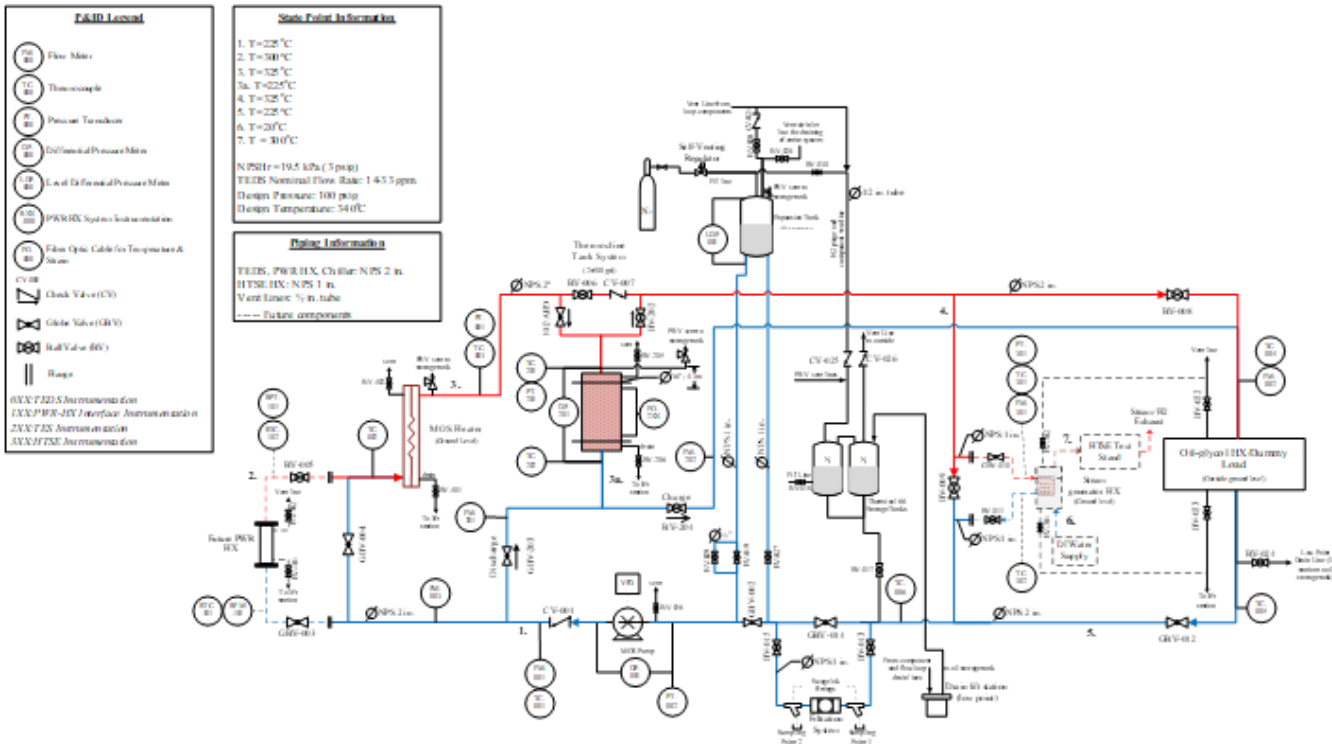

Therminol-66 serves as the working fluid in TEDS. Therminol-66 is a hydrogenated terphenyl that is noncorrosive, has low vapor pressure, large working temperature range, and widespread use as a heat transfer fluid. To monitor system parameters, INL incorporated a combination of flow sensors, pressure sensors, and thermocouples into the TEDS design. Stainless steel construction allows probes to operate up to 1250°C, which supports the maximum 325°C operating temperature.

DETAIL includes additional energy systems such as an integrated microgrid and renewable energy systems including solar photovoltaics.

### High Temperature Electrolysis (HTE) demonstration facility (hydrogen generation)

Figure 1.3 shows a schematic of the HTE system. Major components include: air compressor, air filter/dryer, high-temperature air heater, furnace (hot zone), high temperature electrolysis stacks, hydrogen gas cylinder, safe gas cylinder, nitrogen dewar, mass flow controllers, superheated heated steam generator (atmospheric pressure), steam generator heat exchanger (phase 2), steam superheater (phase 2), exhaust steam-hydrogen cooler (air-cooled), residual steam condensers, chiller, hydrogen recycle compressor, counterflow heat exchanger, and a hydrogen storage tank. A co-located deionized water supply furnishes liquid water feedstock to the steam generator systems. A chiller supplies cooling for the condensers. The system includes a nitrogen supply for carrier gas and system purging. Commercial vendors supply major system components. A ventilated enclosure houses hydrogen-containing components and piping. The chiller is located outside of the enclosure. Support systems supply electrical power for electrolysis and other components, feedstock gases, sweep gas, and appropriate exhaust handling.

Figure 1.3. Schematic of HTE Demonstration Facility



# DOE-ID NEPA CX DETERMINATION

## Idaho National Laboratory

Process piping: SS316 tubing (low-T) or SS310 pipe (high-T)  
 Also PFA (275 psig) for DI water and N<sub>2</sub> between dewar and MFC  
 Process Piping Code: ASME B31.3 (applied where applicable)  
 Piping assembly: qualified pressurized system assembler

See separate P&ID for H<sub>2</sub> compressor and HX condensate drain system

Tubing Wall Thicknesses		Pipe Wall Thicknesses:	
1/4-in:	0.035"	(Std Schedule 40)	
3/8-in:	0.035"	1/2-in:	0.109"
1/2-in:	0.065"	3/4-in:	0.113"
1-in:	0.083"	1-in:	0.133"

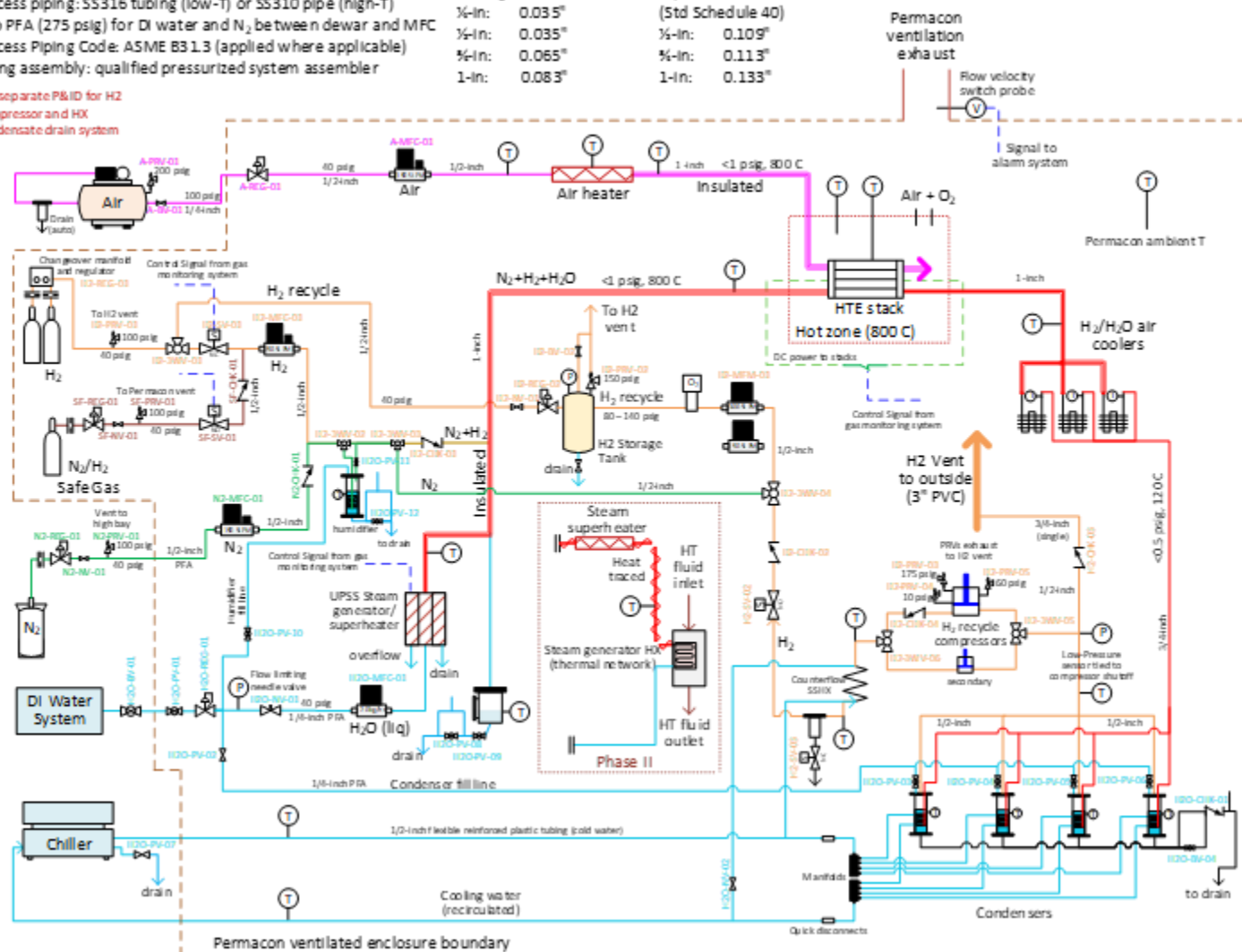

For hydrogen production, the system introduces a mixture of steam and hydrogen (and possibly nitrogen) to the cathode side of the HTE stacks, typically with a volumetric composition of 90% steam and 10% hydrogen. Nitrogen is sometimes also included in the cathode inlet gas mixture. Using nitrogen allows independent variation of the partial pressures of the other process gases while operating at atmospheric pressure. Nitrogen also serves as purge gas to purge air and oxygen out of the stacks and the hydrogen exhaust line prior to and following system operation. A compressed gas cylinder or dewar supplies nitrogen. The stack inlet requires hydrogen at all times to maintain reducing conditions on the nickel cermet cathode. During startup a compressed gas cylinder supplies this hydrogen from a compressed gas cylinder. However, during long-term operation, inlet hydrogen will be supplied via recycle of electrolytically produced hydrogen from the stack exit flow back to the stack inlet. The hydrogen recycle system includes the condensers, hydrogen recycle compressors, water trap, counterflow heat exchanger, and a hydrogen storage tank.

The system has two hydrogen recycle compressors. The large compressor has a rated flow rate of 6.5 SCFM (184 SLPM) at a discharge pressure of 150 psig; it is sized for the full 25 kW HTE operations. The small compressor is rated at 18 SLPM (0.64 SCFM) flow at a discharge pressure of 75 psig; it is sized for 5 kW HTE operations. Pressure in the hydrogen storage tank cycles between 80 psig and 140 psig for the large compressor and between 50 and 75 psig for the smaller. The hydrogen recycle storage tank is rated for 150 psig. The tank is fitted with a pressure relief valve that will lift at 150 psig and vents to the roof. Gas pressure on the downstream side of the regulators will be set at approximately 40 psig to maintain inlet pressure for the mass flow controllers. Pressure relief valves (PRVs) are included downstream of the regulators as a safeguard against inadvertent over-pressure setting on the regulator or regulator failure. Flow-restricting orifices are positioned in the gas lines just downstream of the compressed gas cylinders to ensure that the PRV discharge lines can handle the maximum possible gas flow in the unlikely event of a regulator failure at full-open. During HTE operation, oxygen is produced on the anode side of the HTE stacks. Air is used as a sweep gas on the anode side to carry away this oxygen. Flow rates of nitrogen, hydrogen, and air are set and controlled by precision mass-flow controllers.

An inductively heated atmospheric-pressure steam generator produces steam. The steam generator heats steam up to 850°C. The system mixes hydrogen (and possibly nitrogen) with the steam downstream of the steam generator so that a gas mixture of steam and hydrogen is introduced to the HTE stack. HTE operation electrochemically reduces some of the steam (typically 60%) to hydrogen, which enriches the cathode gas mixture exiting the stack with hydrogen. An air-cooled heat exchanger cools exhaust gas cooled to ~150°C. The condenser removes most residual steam, and a H<sub>2</sub> vent (3-

inch PVC) releases the majority of the remaining gas. During long-term operation, a fraction of the hydrogen exhaust gas is drawn from the H<sub>2</sub> vent line, pressurized, dried, and recycled to the inlet. Cold water supplied by the chiller cools the condenser units.

The DI water system supplies water to the steam generator. The high temperature high pressure flow loop and the HTE share the DI water system. The steam generator unit controls the water inflow rate according to the steam generation rate setpoint. This setpoint is adjustable from 25 – 100% of the maximum rated steam production rate of 10 kg/hr. A precision mass-flow meter monitors the inlet liquid water flow rate. The steam generator also measures the steam production rate. A small fraction of the liquid water supplied to the steam generator unit is excess and is released through the steam generator overflow line.

The TEDS also serves as a second independent steam generating method. TEDS transfers heat from the high temperature high pressure water loop or another thermal energy source to the steam generator heat exchanger for producing steam. The steam exiting this heat exchanger will be at atmospheric pressure and a temperature of ~275°C. This steam requires a separate steam superheater to increase its temperature to 800°C prior to mixing with hydrogen.

A feedback-controlled high-temperature furnace maintains the solid-oxide electrolysis stacks at desired operating temperature (800 to 900°C). The system does not require pressure relief downstream of the steam generator because no valves are located downstream of it. Similarly, pressure relief is not required on the air side downstream of the mass flow controller. Sweep gas air is exhausted to the enclosure through vents located near the enclosure exhaust on top of the furnace. The H<sub>2</sub> exhaust line vents hydrogen outside.

Figure 1.4 shows a 3D CAD view of the HTE demonstration facility with the components inside the enclosure. The equipment is mounted on a set of two skids, each 16 ft. x 10 ft. The figure shows large components including the air compressor, ventilated enclosure, steam generator, furnace, electrolyzer outlet finned-tube coolers, condensers, chiller, hydrogen recycle compressor, hydrogen recycle tank, plus the electrical panels and an instrument rack. The ventilated enclosure includes a gas monitoring system for hydrogen and oxygen levels inside the ventilated enclosure. The enclosure will be continuously ventilated whenever testing is in progress, drawing air from the room and exhausting it to the outside. The ventilation system includes an airflow switch that generates an alarm signal if flow is lost. The gas monitoring system also activates an alarm if it detects hydrogen or elevated oxygen. The alarm signals interact with a solenoid valve on the hydrogen gas supply line that shuts off inlet flows when the alarm activates. In addition, the system also shuts off power to the electrolyzer to stop hydrogen production in the stacks. The alarm also initiates flow of “safe gas” through the cathode side of the stacks. Safe gas is a mixture of nitrogen and hydrogen (3.96% H<sub>2</sub>) that flows through the cathode side of the electrolysis stacks to prevent oxidation damage to the cathodes during an alarm. In addition to the automated interlock features of the gas monitoring system, the system notifies laboratory occupants of potentially hazardous gas buildup. The system has relay outputs, display readout, visual and audible alarms and an auto dialer.

#### **Real-time Virtual Linkage with Multiple Test Facilities**

INL proposed to develop data acquisition and instrument control for DETAIL systems. These control systems communicate with multi-channel data acquisition hardware to read and store experimental data from all of the system instrumentation at a user-specified rate. They can also communicate with analog and digital output hardware to control loop operational parameters such as flow rates, heater power, and fluid temperature based on manual user input or built-in control algorithms.

Figure 1.4. The Demonstration System Layout.

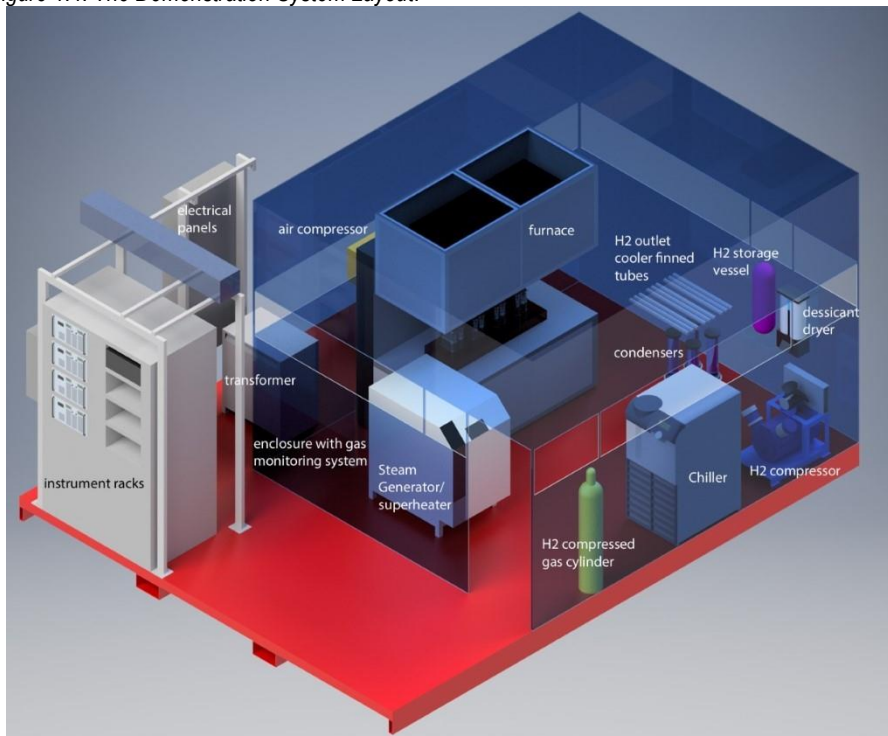

# DOE-ID NEPA CX DETERMINATION

## Idaho National Laboratory

### Air Emissions

Note: If this project or activity produces or causes air emissions, and it is not stated in this ECP how those emissions caused by this project or activity are exempt, then an APAD is required for documentation. Project activities have the potential to release hazardous and chemical contaminants into the air. Construction activities generate minor emissions from welding, adhesives, cleaners, and solvents. Operating DETAIL emits hydrogen, nitrogen and steam. These emissions are not regulated by the state of Idaho. Regulatory requirements will be determined prior to commencing modification of facilities using the APAD process. Project activities also have the potential to release refrigerants and greenhouse gases.

### Discharging to Surface-, Storm-, or Ground Water

Air conditioner (AC) condensers have the potential to discharge water to the ground.

Activities involving drainage or runoff (e.g., parking lots) may result in storm water discharges.

Project activities have the need to store oil in oil-filled operational equipment or in bulk storage containers at REC that is above 55 gallons. ESL is currently under the threshold of requiring an SPCC plan and the proposed quantity for this project keeps ESL under that threshold. If additional oil storage is needed for the project, an SPCC plan may be required.

### Disturbing Cultural or Biological Resources

N/A

### Generating and Managing Waste

Industrial waste in the form of scrap wood, scrap metal, packaging material, Resource Conservation and Recovery Act (RCRA) empty chemical containers, rags, insulation, wire, carpet scrap, tile scrap, drywall, pipe scrap, etc., will be generated during the project.

Hazardous waste generation has the potential to be generated from paint waste, adhesive waste, cleaning solvents, and spill material.

All waste generated during the project will be characterized, stored, and disposed at the direction of Waste Generator Services (WGS).

### Releasing Contaminants

Chemicals will be used and will be submitted to chemical inventory lists with associated Safety Data Sheets (SDSs) for approval prior to use. The Facility Chemical Coordinator will enter these chemicals into the INL Chemical Management Database. All chemicals will be managed in accordance with laboratory procedures. When dispositioning surplus chemicals, project personnel must contact the facility Chemical Coordinator for disposition instructions.

Although not anticipated, there is a potential for spills when using chemicals. In the event of a spill, notify facility Environmental Staff. If the Environmental Staff cannot be contacted, report the release to the Spill Notification Team (208-241-6400). Clean up the spill and turn over spill cleanup materials to WGS.

### Using, Reusing, and Conserving Natural Resources

All applicable waste would be diverted from disposal in the landfill when possible. Program personnel would use every opportunity to recycle, reuse, and recover materials and divert waste from the landfill when possible. The program would practice sustainable acquisition, as appropriate and practicable, by procuring construction materials that are energy efficient, water efficient, are bio-based in content, environmentally preferable, non-ozone depleting, have recycled content, and are non-toxic or less-toxic alternatives.

<p><b>SECTION D. Determine Recommended Level of Environmental Review, Identify Reference(s), and State Justification:</b> Identify the applicable categorical exclusion from 10 Code of Federal Regulation (CFR) 1021, Appendix B, give the appropriate justification, and the approval date.</p>
---

For Categorical Exclusions (CXs), the proposed action must not: (1) threaten a violation of applicable statutory, regulatory, or permit requirements for environmental, safety, and health, or similar requirements of Department of Energy (DOE) or Executive Orders; (2) require siting and construction or major expansion of waste storage, disposal, recovery, or treatment or facilities; (3) disturb hazardous substances, pollutants, contaminants, or Comprehensive Environmental Response, Compensation, and Liability Act (CERCLA)-excluded petroleum and natural gas products that pre-exist in the environment such that there would be uncontrolled or unpermitted releases; (4) have the potential to cause significant impacts on environmentally sensitive resources (see 10 CFR 1021). In addition, no

**DOE-ID NEPA CX DETERMINATION**  
**Idaho National Laboratory**

extraordinary circumstances related to the proposal exist that would affect the significance of the action. In addition, the action is not "connected" to other action actions (40 CFR 1508.25(a)(1)) and is not related to other actions with individually insignificant but cumulatively significant impacts (40 CFR 1608.27(b)(7)).

**References:**

10 CFR 1021, Appendix B to subpart D, items B3.6, "Small-scale research and development, laboratory operations, and pilot projects" and B1.31 "Equipment installation."

**Justification:**

The proposed R&D activities are consistent with CX B3.6 "Siting, construction, modification, operation, and decommissioning of facilities for small-scale research and development projects; conventional laboratory operations (such as preparation of chemical standards and sample analysis); smallscale pilot projects (generally less than 2 years) frequently conducted to verify a concept before demonstration actions, provided that construction or modification would be within or contiguous to a previously disturbed area (where active utilities and currently used roads are readily accessible). Not included in this category are demonstration actions, meaning actions that are undertaken at a scale to show whether a technology would be viable on a larger scale and suitable for commercial deployment;" and

B1.31 "Installation or relocation and operation of machinery and equipment (including, but not limited to, laboratory equipment, electronic hardware, manufacturing machinery, maintenance equipment, and health and safety equipment), provided that uses of the installed or relocated items are consistent with the general missions of the receiving structure. Covered actions include modifications to an existing building, within or contiguous to a previously disturbed or developed area, that are necessary for equipment installation and relocation. Such modifications would not appreciably increase the footprint or height of the existing building or have the potential to cause significant changes to the type and magnitude of environmental impacts."

Is the project funded by the American Recovery and Reinvestment Act of 2009 (Recovery Act)       Yes     No

Approved by Jason Sturm, DOE-ID NEPA Compliance Officer on: 1/13/2021